

# CONTAINER CARRIER CC-40-3-S



(The picture is not the standard execution)



## Technische gegevens

Geschikt voor  
Schoteldruk  
Maximale aslast per as  
Totaal toegestane massa  
Leeggewicht  
Nuttig laadvermogen  
Schotelhoogte  
Chassishoogte  
Bandenmaat  
Elektrische aansluitingen  
Terug naar rijhoogte



## Technische Daten

Geeignet für  
Sattellast  
Max. Achslast pro Achse  
Gesamt zulässige Masse  
Leergewicht  
Nutzlast  
Sattelhöhe  
Chassishöhe  
Reifengröße  
Elektrische Anschlüsse  
Zurück zur Fahrhöhe



## Technical data

Suitable for  
Kingpin weight  
Maximal Axleload / axle  
Gross trailer weight  
Empty weight  
Payload  
Fifthwheel height  
Chassisheight  
Tyresize  
Electrical connectors  
Reset to Ride (RTR)

## CC-40-3-S

40ft HC  
14.000 kg  
9.000 kg  
41.000 kg  
3.700 kg  
37.300 kg  
1.110 mm  
1.110 mm  
385/55 R22,5  
2x 7-pin + 1x 15 pin  
( >16 km)

**OPTIES / OPTIONEN / OPTIONS**

17-7-2

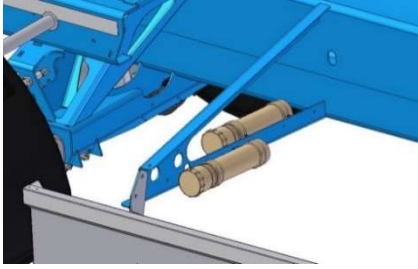

07-28

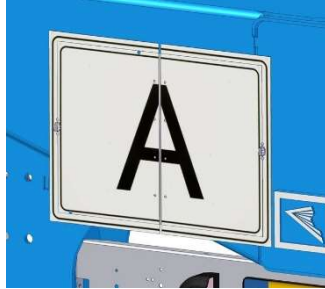

07-5



15-14

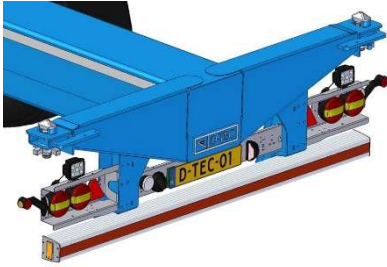

15-4-07



21-10

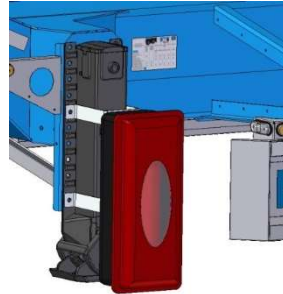

07-NS-17

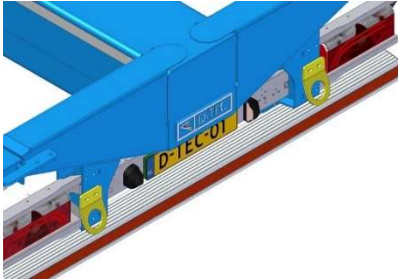

07-NS-17

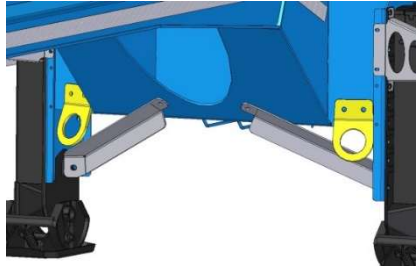

07-NS-12/13/14



09-5-13

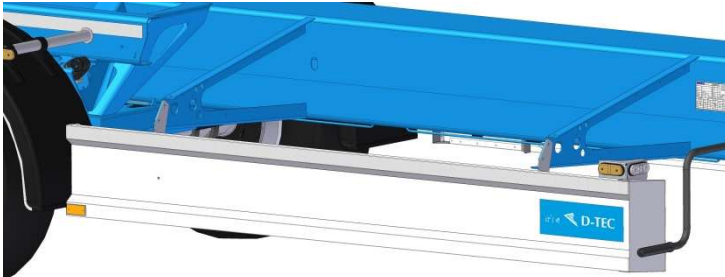

21-16

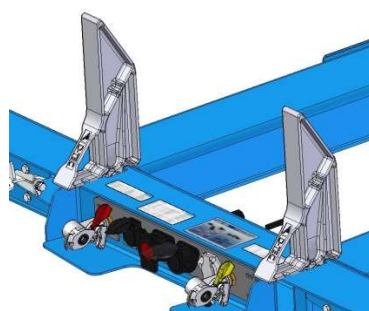

|          |  |  |  |
|----------|-----------------------------------------------------------------------------------|-----------------------------------------------------------------------------------|-----------------------------------------------------------------------------------|
|          | <b>Basis opties</b>                                                               | <b>Basis Optionen</b>                                                             | <b>Basic options</b>                                                              |
| 11-4-15  | Valx trommelrem                                                                   | Valx Trommelbremsen                                                               | Valx drum brakes                                                                  |
| 19-55    | Bandenmaat 385/55R22,5                                                            | Reifengröße 385/55 R22,5                                                          | Tyresize 385/55 R22,5                                                             |
| 19-B     | Banden DoubleStar                                                                 | Reifen DoubleStar                                                                 | Tyres DoubleStar                                                                  |
| 09-6-DTM | 1 laag 2K natlak RAL 5015                                                         | 1 Schicht 2K RAL 5015                                                             | 1-Layer coating 2K RAL 5015                                                       |
| 21-16    | Containerstops                                                                    | Containerstops                                                                    | Containerstops                                                                    |
|          | <b>Comfort opties</b>                                                             | <b>Komfort Optionen</b>                                                           | <b>Comfort options</b>                                                            |
|          | Valx / Mercedes-Benz / Saf Schijf<br>BPW trommelremmen                            | Valx / Mercedes-Benz / Saf Scheibe<br>BPW Trommelbremsen                          | Valx / Mercedes-Benz / Saf disc<br>BPW drumbrakes                                 |
| 11-FT-1  | As 1 lifas automatisch                                                            | Achse 1 Liftachse automatisch                                                     | Axle 1 liftaxle automatic                                                         |
| 21-5     | 2 Wielkeggen                                                                      | 2 Radkeile                                                                        | 2 Wheelwedges                                                                     |
| 07-3     | Kingpenslohouder                                                                  | Halter für Königszapfenverriegelung                                               | Holder for kingpinlock                                                            |
| 07-5     | Gevaarlijke stoffen bord                                                          | Gefahrsgutschild                                                                  | ADR sign at the rear                                                              |
| 07-28    | A-bord                                                                            | A-Schild                                                                          | A-Sign                                                                            |
| 09-1-1   | Volledig schooperen                                                               | Völlig spritzverzinkt                                                             | Full schooping                                                                    |
| 09-1-2   | Bovenzijde schooperen<br>Standard Coating in RAL 3002,                            | Oberseite spritzverzinkt<br>RAL 5002, RAL 5010, RAL 5015,                         | Topside schooping<br>RAL 7016, RAL 7021, RAL 9005                                 |
| 17-7     | Documenten koker uit plastic                                                      | Dokubox Kunststoff                                                                | Document tube                                                                     |
| 17-7-2   | Documenten koker uit plastic (2x)<br>Continental HTR2 / Hankook                   | Dokubox Kunststoff (2x)<br>Goodyear LHT II / Bridgestone                          | Dokubox Kunststoff (2x)<br>Michelin                                               |
| 21-8     | Kingpinslot                                                                       | Königszapfenverriegelung                                                          | Kingpinlock                                                                       |
| 21-10    | Houder zonder 6 kg brandblusser                                                   | Halter ohne 6kg Feuerlöscher                                                      | Holder without 6kg fire extinguisher                                              |
| 03-4-A   | ADR-fabrikantverklaring                                                           | ADR Herstellerbestätigung                                                         | ADR Manufacturer certificate                                                      |
| 09-5-13  | Dichte zijafscherming in kleur wit                                                | Unterfahrschutz in Farbe, weiß                                                    | Tight side protection in colour, white                                            |
| 09-5-14  | Dichte zijafscherming in chassis kleur                                            | Anfahrschutz in Chassis Farbe                                                     | Tight side protection in chassis colour                                           |
| 07-NS-17 | Ferry ringen                                                                      | Ferry rings                                                                       | Ferryrings                                                                        |
| 19-65    | Bandenmaat 385/65R22,5                                                            | Reifengröße 385/65 R22,5                                                          | Tyresize 385/65 R22,5                                                             |
| 15-14    | 4 ronde 3-kamer lampen                                                            | 4 runde Rückleuchten                                                              | 4 round 3 chamber rear lights                                                     |
| 15-16    | Alle lampen in LED uitvoering                                                     | Komplette Beleuchtung in LED                                                      | All lights at the rear in LED                                                     |
| 15-4-07  | LED werklichten achter<br>D-TEC spatlap blauw / zwart / wit                       | LED Arbeitsscheinwerfer am Heck<br>Schmutzfänger blau / schwarz / weiß            | LED worklights at the rear<br>D-TEC mudflap blue / black / white                  |
| 19-7-3   | Alcoa Durabright 6 alu velgen                                                     | Alcoa Durabright 6 alu Felgen                                                     | Alcoa Durabright 6 alloy rims                                                     |
| 21-7     | Hubodometer op de middelste as                                                    | Hubodometer auf der Mittelachse                                                   | Hubodometer on the middle axle                                                    |
| 25-NS-2  | LZV uitgevoerd en gekeurd                                                         | nur für NL                                                                        | only NL                                                                           |
| 11-18    | Multifunctioneel display                                                          | Multifunktionsdisplay                                                             | Multifunction display                                                             |
| 21-22    | Ophangsteun containerstops                                                        | Behälter Containereinweiser                                                       | Support for containerstops                                                        |

